



# REMEDY 355 RITMO TRACK MACHINE



# SMALL DIAMETERS FUSION

REMEDY 355 is an independent, high-productivity welding machine driven by tracks and powered by a Diesel on-board generator. Designed for butt welding HDPE and PP pipes from  $\varnothing$  125 to 355 mm (from 4" to 14" IPS; from 4" to 12" DIPS).

Suitable for ISO 21307 High Pressure and ASTM F2620 fusion standards.

**HIGH  
PRODUCTIVITY**

**INDEPENDENT**

**DIESEL ENGINE  
ON-BOARD  
GENERATOR**



# OUR SMART SOLUTION

## VERSATILE

- Working range  
from  $\varnothing$  125 to 355 mm  
from  $\varnothing$  4" to 14" IPS  
from  $\varnothing$  4" to 12" DIPS
- Materials: HDPE, PP
- Manual controls
- Tracked welding machine
- Drives over 35% slopes
- In-ditch/user friendly
- In-ditch hoses/cables range/length  
7 m - 23 ft

## ACCURATE

- Designed to weld according to:  
ISO 21307 High Pressure  
ASTM F2620 standards
- Removable auxiliary panel to control  
facers/heating plate
- Easily welds fittings/quick set-up time
- Heating plate with a high temperature  
protection
- Spotlights on welding area
- Insert with fast-locking system

## COMPLETE

- Self-propelled on track
- Self-contained generator on-board
- Heater/facer on-board
- Patented System to open/close  
Heating plate and Facer
- Hydraulic side rollers
- Facer with safety microswitch

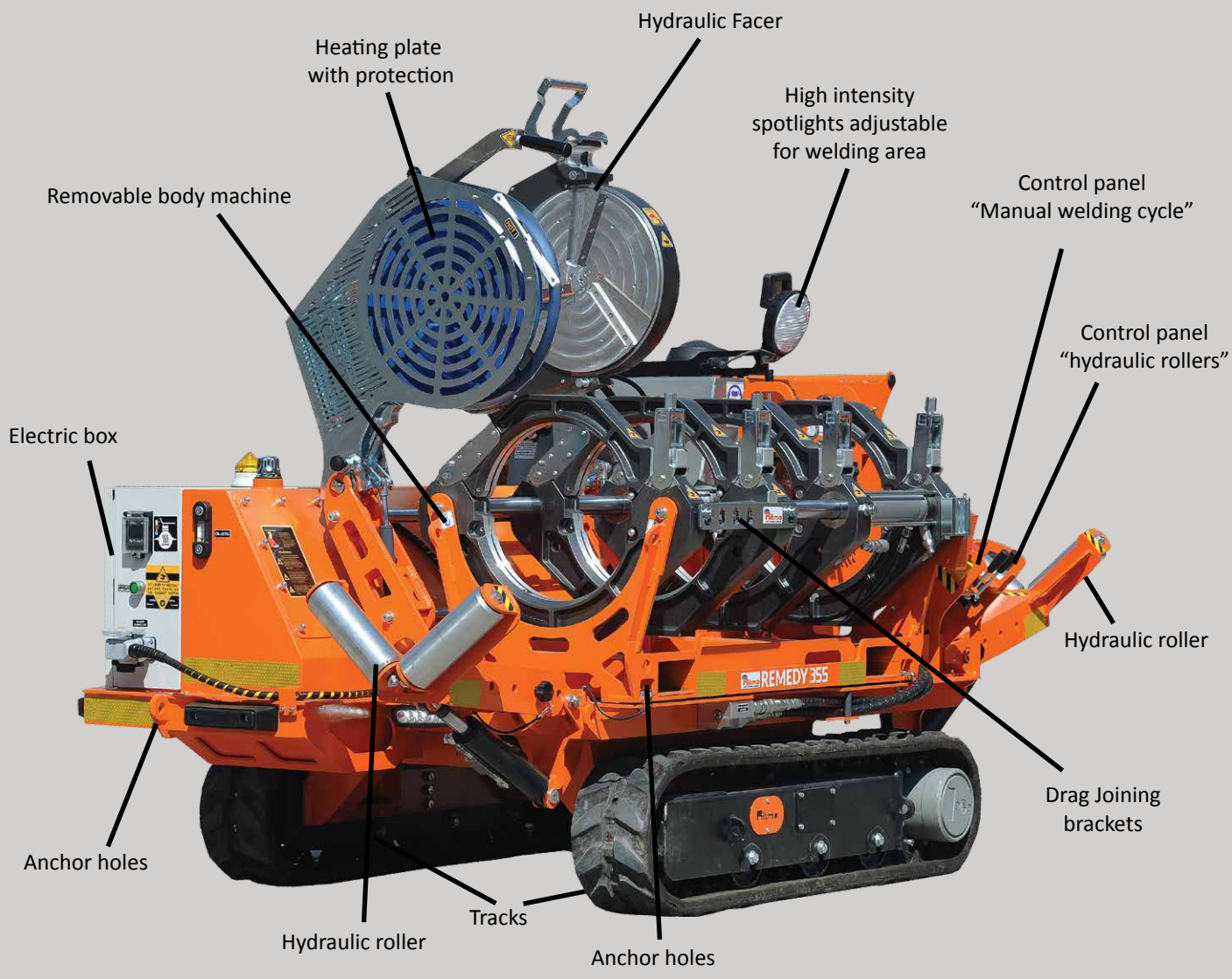

Machine Carriage Easily Removable for In-Ditch Use

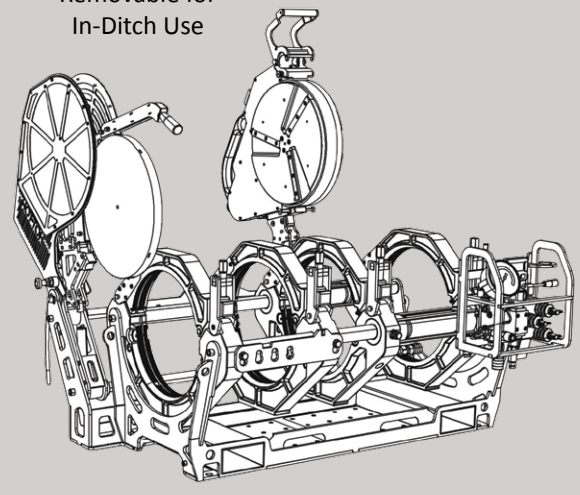

Tracks along with an On-Board Generator

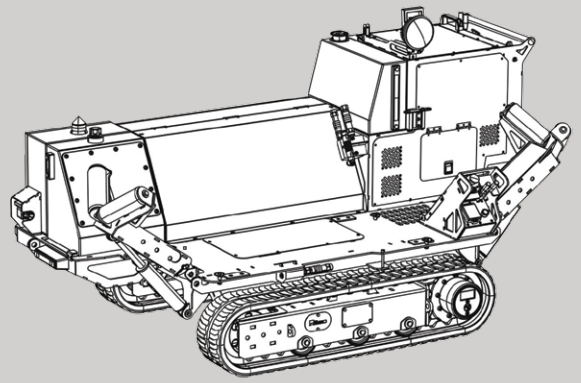



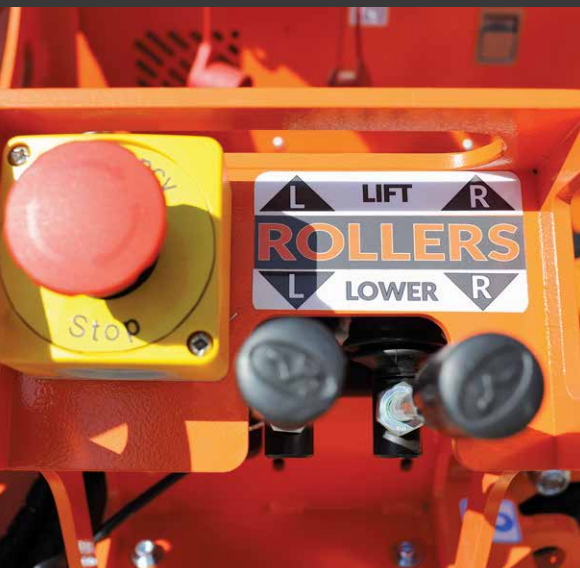
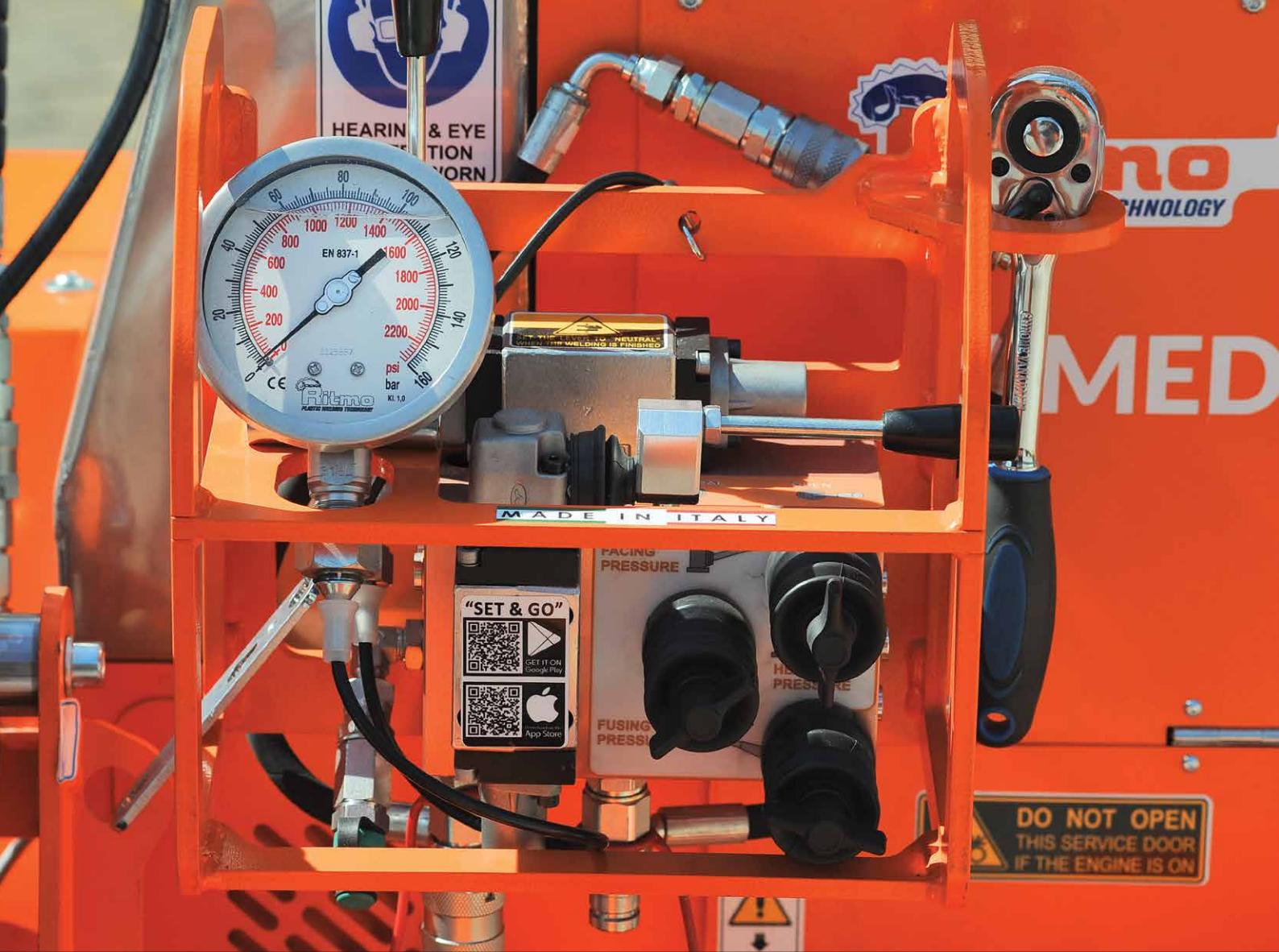

# ALL IN YOUR HANDS

## FREE TO CONTROL

Remedy 355 is available with Manual Welding Control System. Intuitive control panel allow an easy management of the welding cycle and every phase is manually controlled.



# THE REMEDY LINE

## TOTAL MOBILITY ON JOBSITE

Remedy line are high-productivity welding machines driven by tracks. Design and Technology Made in Italy.

## FUSION SOLUTION LARGE - MEDIUM - SMALL



### REMEDY 1000

HDPE and PP pipes  
Ø 355 mm to 1000 mm  
14" IPS ÷ 36" DIPS



### REMEDY 500

HDPE and PP pipes  
Ø 200 mm to 500 mm  
6" ÷ 20" IPS  
6" ÷ 18" DIPS



### REMEDY 355

HDPE and PP pipes  
Ø 125 mm to 355 mm  
4" ÷ 14" IPS  
4" ÷ 12" DIPS





## TECHNICAL FEATURES

Working range	125 ÷ 355 mm 4" ÷ 14" IPS 4" ÷ 12" DIPS
Materials	HDPE, PP For other materials contact RITMO S.P.A.
On board generator	719 cc - 14 kW
Emmission compliance	EPA US TIER 4 FINAL, UE STAGE V
Fuel	Diesel
Fuel tank	43 Litres (11.3 gal)
Autonomy	21 Hours
Hourly consumption	max 2 Liters (0.52 gal)
Max operator side noise	78 dB
Tracks driving speed	1.5 Km/h or 3 Km/h (0.93 mph or 1.86 mph)
Width of tracks	180 mm (7.08")
Max operating slope	35%
Max dimensions on site (W x D x H) Remedy 355 standard composition	3007 x 1479 x 1690 mm 9.86 x 4.85 x 5.54 ft
Max dimensions on shipping (W x D x H)	2340 x 1364 x 1219 mm 7.67 x 4.47 x 4 ft
Weight boby machine for in-ditch use	920 Kg (2028 lb)
Weight Remedy 355 standard composition	1170 Kg (2579 lb)

### RITMO S.P.A

Via A Volta, 35/37 - Bressio di Teolo (Padova) Italy

Ph. + 39 049 9901888 Fax +39 049 9901993 - info@ritmo.it - www.ritmo.it